

VERTICAL FORM-FILL-SEAL MACHINE

The complete packaging process—from bag forming, filling, heat-sealing, date coding, and cutting are all done automatically.



HW-1372



FEATURES:

- ▲ Intermittent motion sealing ensures the perfect sealing.
- ▲ Simple and easy for operation.
- ▲ A wide variety of filling systems is available.

DIMENSIONAL DRAWING:

MODEL:HW-1372

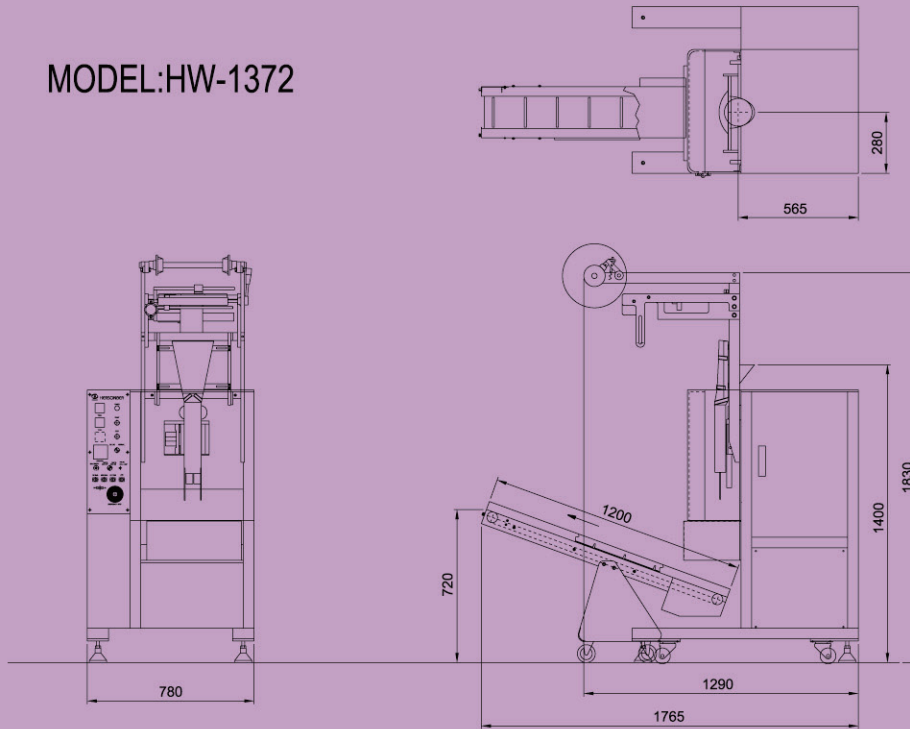

SPECIFICATIONS:

MODEL	HW-1172	HW-1372
PACKAGING STYLE	PILLOW TYPE SEAL	
BAG WIDTH	30-130 MM	60-180 MM
BAG LENGTH	40-175 MM	80-280 MM
MAXIMUM FILM WIDTH	290 MM	390 MM
MAXIMUM FILM REEL DIAMETER	300 MM	300 MM
OPERATING SPEED	20-60 BAGS/MIN	15-40 BAGS/MIN
FILM MATERIAL	ANY LAMINATED HEAT SEALABLE FILM	
FEEDING SYSTEM	AUGER FILLER CONVEYOR VOLUMETRIC CUPS SINGLE/TWIN/FOUR HEAD WEIGHER MULTIHEAD COMBINATION WEIGHER	
OPTION	CODER FOR PRINTING DATE HOLE PUNCH NITROGEN FEEDING	



HERSONBER INDUSTRIAL CO., LTD.

No. 18 Lane 156, Feng Nan St., Feng Yuan, Taiwan.

TEL: +886-4-25235829 FAX: +886-4-25276923

E-mail: hsbpack@seed.net.tw

<http://www.hersonber.com>

AGENT