

# Compact Horizontal Wrapper

Economical flow wrapper for manually feed applications

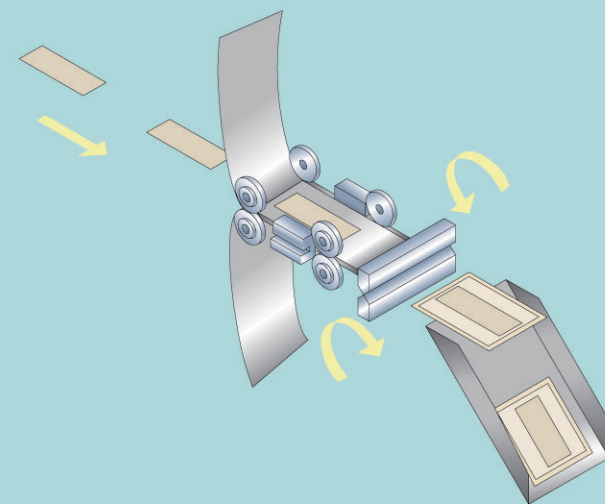
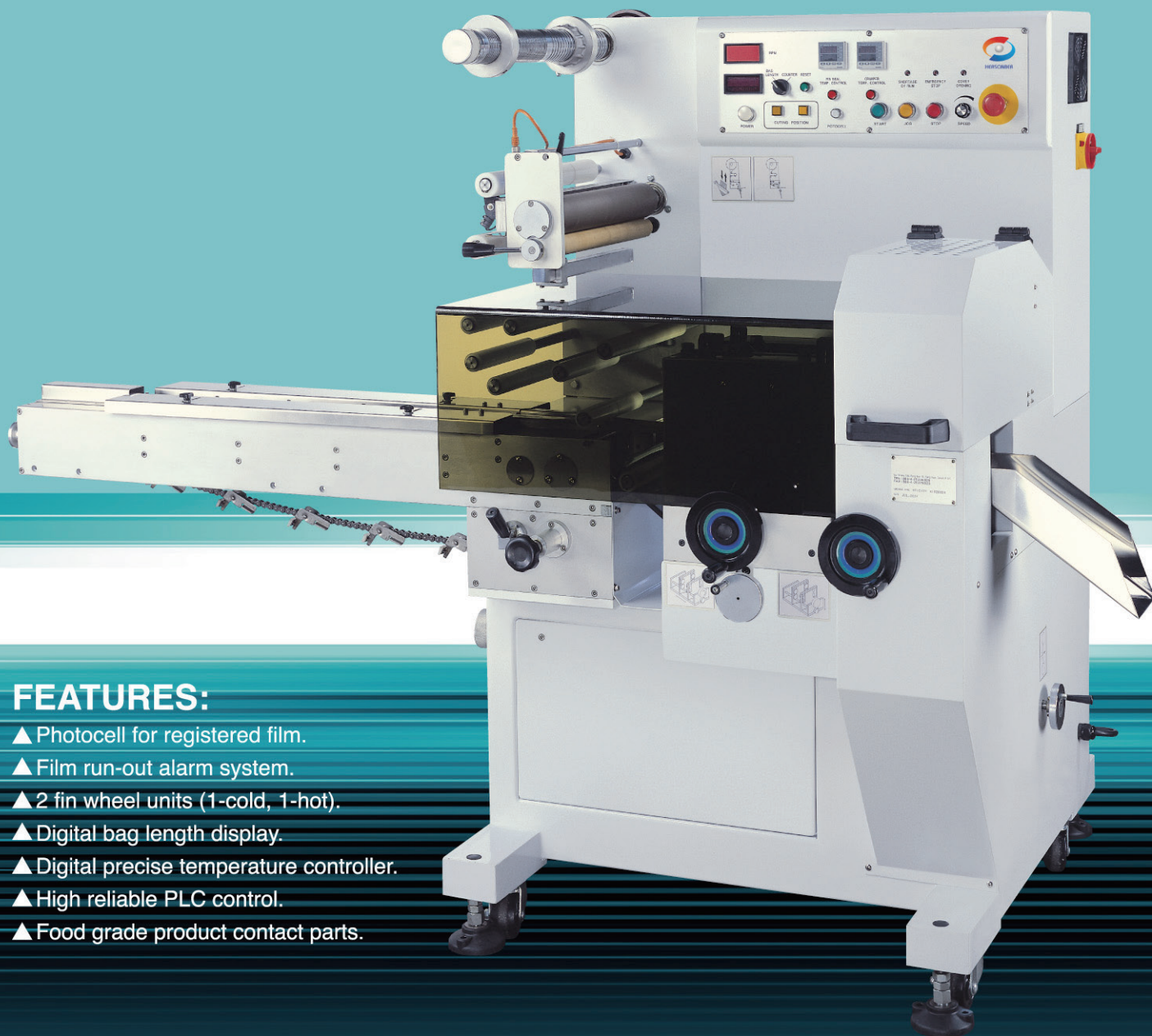

**HW-240M**

## FEATURES:

- ▲ Photocell for registered film.
- ▲ Film run-out alarm system.
- ▲ 2 fin wheel units (1-cold, 1-hot).
- ▲ Digital bag length display.
- ▲ Digital precise temperature controller.
- ▲ High reliable PLC control.
- ▲ Food grade product contact parts.



## DIMENSIONAL DRAWING:

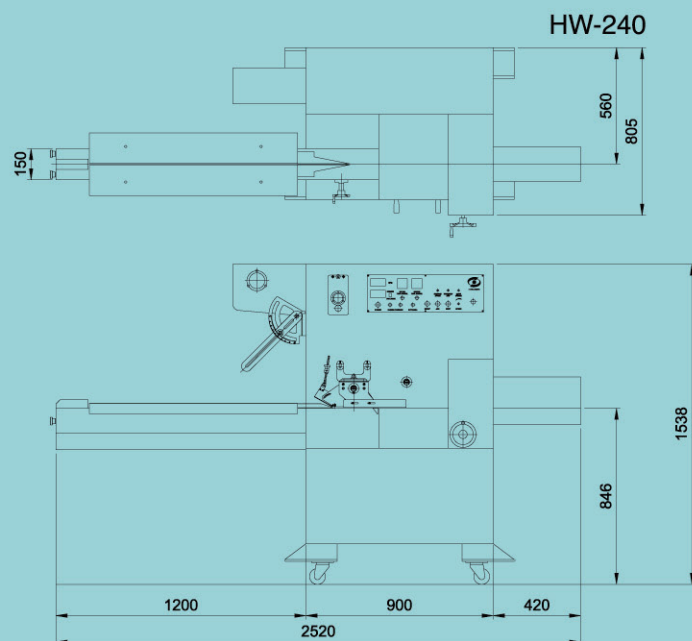

## SPECIFICATIONS:

MODEL	HW-240	HW-240M
PACKAGING STYLE	PILLOW TYPE	4-SIDE SEAL
WRAPPING SIZE	LENGTH	80-320 MM
	WIDTH	20-120 MM
	HEIGHT	60 MM
MAX.FILM WIDTH	400 MM	400 MM
MAX.FILM DIAMETER	Ø 300 MM	Ø 300 MM
MACHINE SPEED	UP TO 120 PACKAGES/MIN	
FILM SPEED	UP TO 30 METERS/MIN	
VOLTAGE	220V, 50/60Hz, SINGLE PHASE STANDARD	
POWER USAGE	10AMPS, 2KW	
MACHINE WEIGHT	760KG	

(Above specification may be different, subject to different inquiry. The manufacturers reserve the right to change design and/or specifications without prior notice. )

## OPTIONAL:

- ▲ Adjustable bag former.
- ▲ Date coder.
- ▲ Stainless steel frame.
- ▲ Package gusseting.
- ▲ Hole punch crimpers.
- ▲ Gas flushing device.
- ▲ Longer infed conveyor.



### HERSONBER INDUSTRIAL CO., LTD.

No. 18 Lane 156, Feng Nan St., Feng Yuan, Taiwan.

TEL: +886-4-25235829 FAX: +886-4-25276923

E-mail: hsbpack@seed.net.tw

<http://www.hersonber.com>

AGENT