

## DIMENSIONAL DRAWING:

HW-260 III

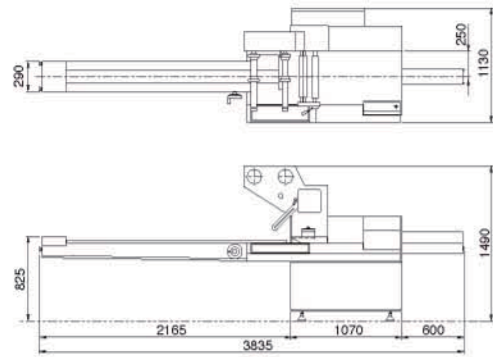

HW-265 III

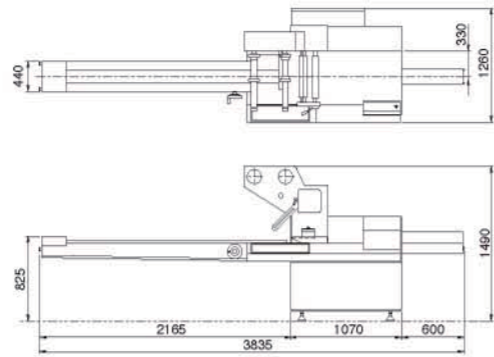

## SPECIFICATIONS:

FUNCTION	STANDARD		
MODEL	HW-260 III	HW-265 III	HW-267 III
PACKAGING STYLE	PILLOW TYPE SEAL		
WRAPPING SIZE	LENGTH 100~320	LENGTH 100~320	LENGTH 100~320
	WIDTH 70~230	WIDTH 70~230	WIDTH 70~230
	HEIGHT 10~100	HEIGHT 5~60	HEIGHT 10~160
MAX. FILM WIDTH	600mm	600mm	600mm
MAX. FILM DIAMETER	Ø300	Ø300	Ø300
OPERATING SPEED	50-150 BAGS/MIN		



# HERSONBER

HIGH SPEED HORIZONTAL FLOW WRAPPER



## HERSONBER INDUSTRIAL CO., LTD.

No. 18 Lane 156, Feng Nan St., Feng Yuan, Taiwan.

TEL: +886-4-25235829 FAX: +886-4-25276923

E-mail: hsbpack@seed.net.tw

<http://www.hersonber.com>

AGENT



# HIGH SPEED HORIZONTAL FLOW WRAPPER

ADVANCED PLC CONTROL WITH TOUCH SCREEN, LABOUR SAVING, LOW MAINTENANCE, QUICK SIZE CHANGE, COST SAVING.

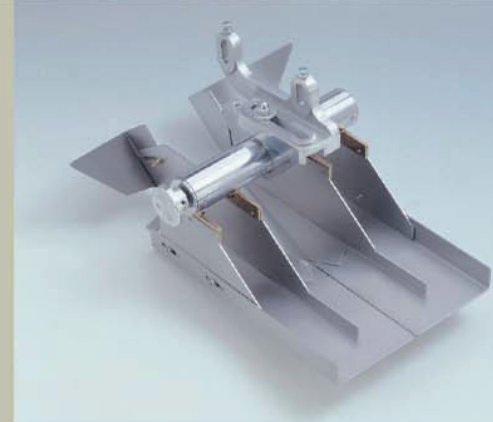
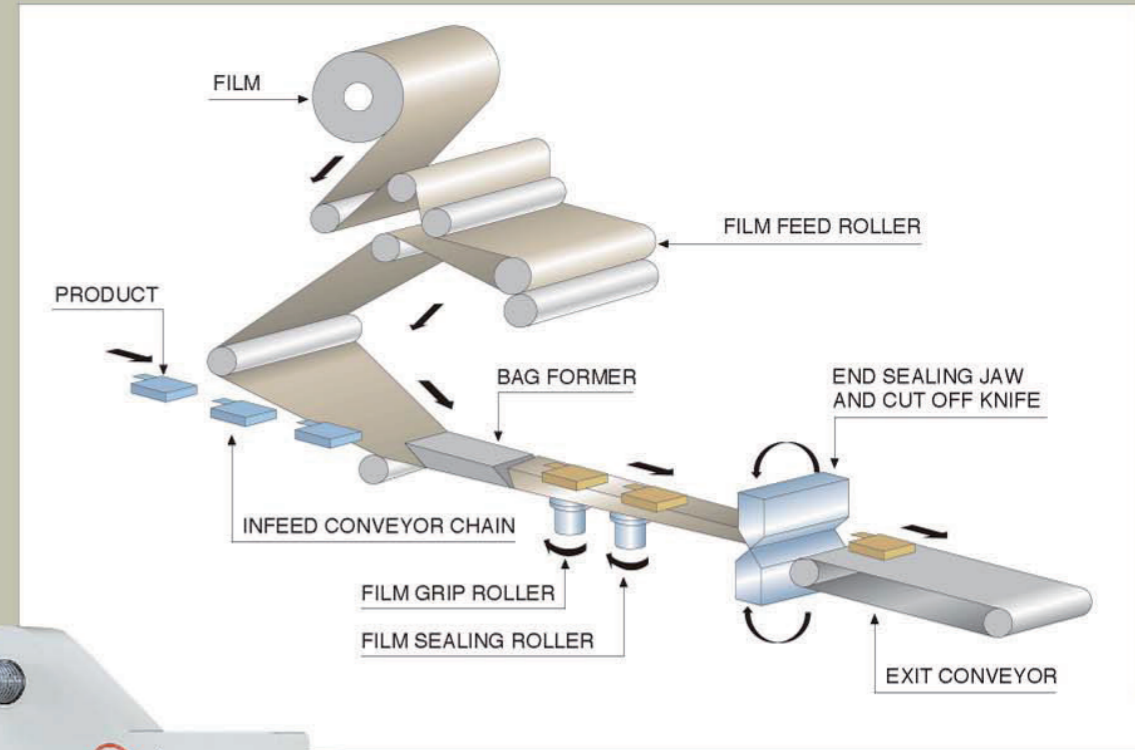

ADJUSTABLE BAG FORMER

HW-260 III



## FEATURES:

- ▲ Twin reels holders with quick release cones.
- ▲ Automatic bag length setting from touch screen input.
- ▲ Variable speed control.
- ▲ Automatic bag length monitoring and adjusting.
- ▲ Automatic opening and closing of long seal and cross seal heaters when machine stops.
- ▲ User friendly touch screen for quick, simple size change.
- ▲ Digital temperature controllers with high and low alarms.
- ▲ Automatic crimp speed synchronisation and adjustment.

## OPTION:

- ▲ Adjustable bag former.
- ▲ Date coder.
- ▲ Stainless steel frame.
- ▲ Automatic film splicer.
- ▲ Package gusseting.
- ▲ Hole punch crimpers.
- ▲ Gas flushing device.
- ▲ Automatic feeders.