

# Horizontal Flow Wrapper

Easy to use, special for loose products without tray

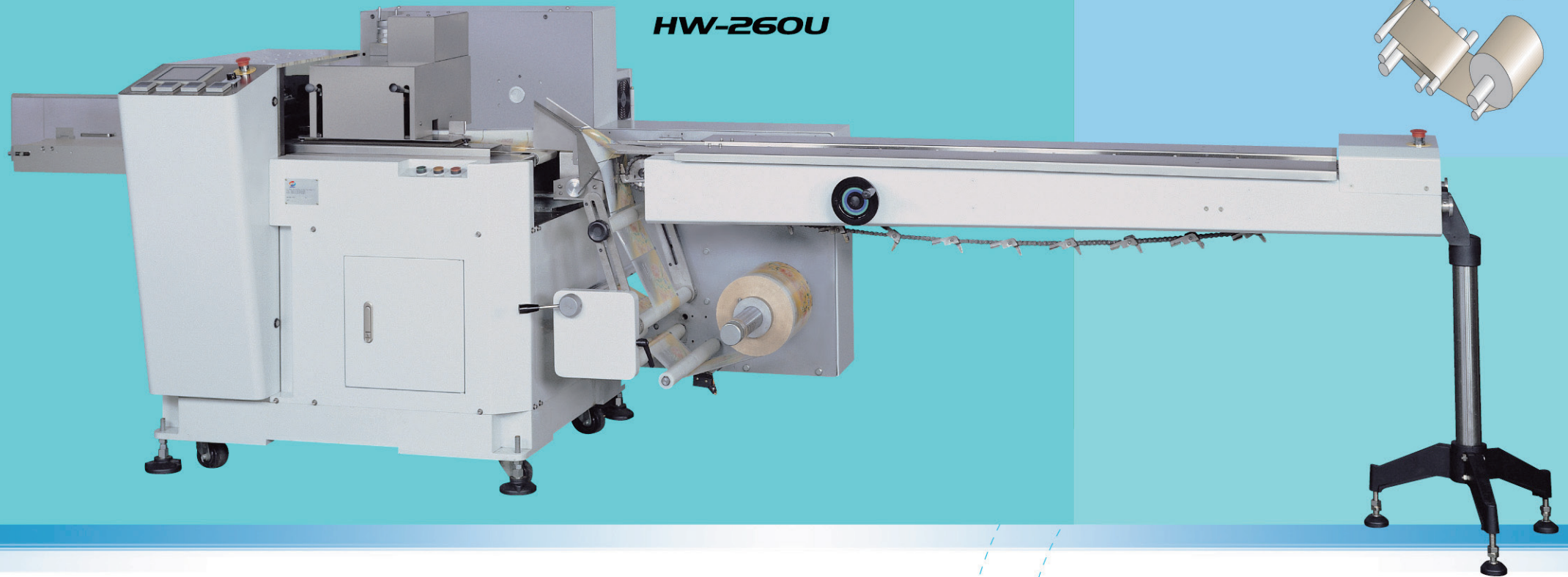

## FEATURES:

- ▲ Bag length setting from touch screen.
- ▲ Automatic bag length adjustment system.
- ▲ 2 fin wheel units with pre-heat.
- ▲ Dual film reel holder with power feed roll.
- ▲ Touch screen for operator interface.
- ▲ High reliable PLC control.
- ▲ Photocell for registered film.
- ▲ Adjustable bag former.
- ▲ Film tension control.
- ▲ Film run-out alarm system.
- ▲ Food grade product contact parts.

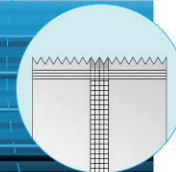

## DIMENSIONAL DRAWING:

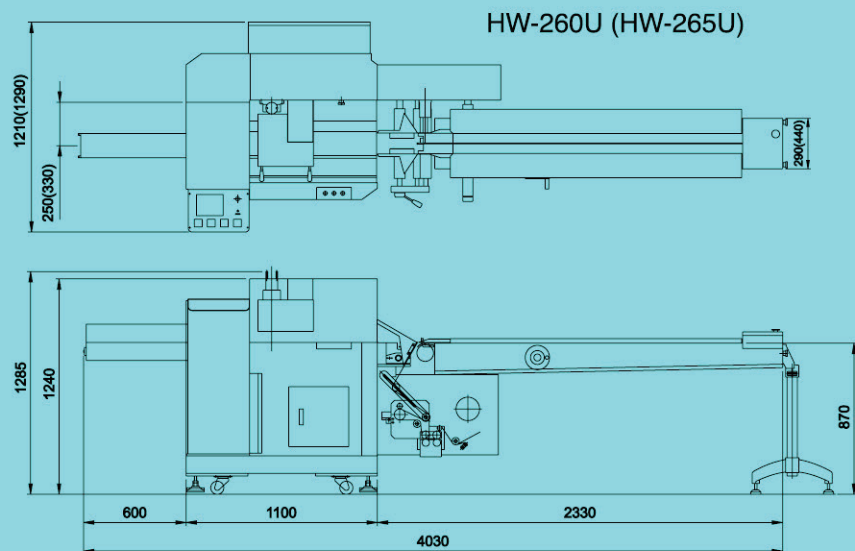

## SPECIFICATIONS:

MODEL		HW-260U	HW-265U
PACKAGING STYLE		PILLOW TYPE	
WRAPPING SIZE	LENGTH	80-320 MM	80-320 MM
	WIDTH	20-120 MM	70-230 MM
	HEIGHT	105 MM	105 MM
MAX.FILM WIDTH		400 MM	600 MM
MAX.FILM DIAMETER		Ø 300 MM	Ø 300 MM
MACHINE SPEED		UP TO 180 PACKAGES/MIN	
FILM SPEED		UP TO 30 METERS/MIN	
VOLTAGE		220V, 50/60Hz, SINGLE PHASE STANDARD	
POWER USAGE		12AMPS, 2.5KW	
MACHINE WEIGHT		960KG	

(Above specification may be different, subject to different inquiry. The manufacturers reserve the right to change design and/or specifications without prior notice.)

## OPTIONAL:

- ▲ Date coder.
- ▲ Gas flushing device.
- ▲ Stainless steel frame.
- ▲ Longer infeed conveyor.
- ▲ Package gusseting.
- ▲ Automatic feeders.
- ▲ Hole punch crimpers.



## HERSONBER INDUSTRIAL CO., LTD.

No. 18 Lane 156, Feng Nan St., Feng Yuan, Taiwan.

TEL: +886-4-25235829 FAX: +886-4-25276923

E-mail: hsbpack@seed.net.tw

<http://www.hersonber.com>

AGENT