

DIMENSIONAL DRAWING:

MODEL:HW-5152

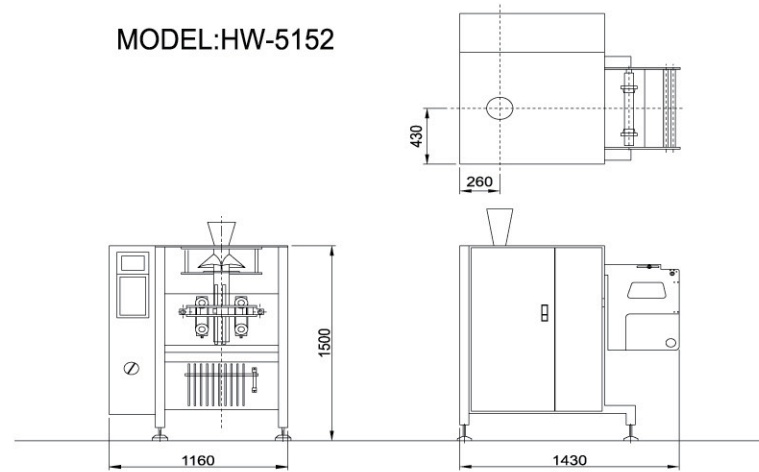
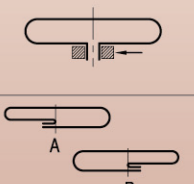
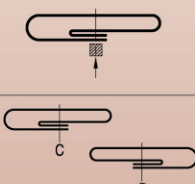

SPECIFICATIONS:

MODEL	HW-5152	HW-5162
PACKAGING STYLE	PILLOW TYPE SEAL	
BAG WIDTH	70-250 MM	100-300 MM
BAG LENGTH	100-350 MM	100-400 MM
MAXIMUM FILM WIDTH	530 MM	630 MM
MAXIMUM FILM REEL DIAMETER	380 MM	500 MM
OPERATING SPEED	25-70 BAGS/MIN	20-60 BAGS/MIN
AIR SUPPLY	6KG/CM ² ,2.5M ³ /MIN	7KG/CM ² ,3M ³ /MIN
TYPE OF SEAL		
FEEDING SYSTEM	AUGER FILLER CONVEYOR VOLUMETRIC CUPS SINGLE/TWIN/FOUR HEAD WEIGHER MULTIHEAD COMBINATION WEIGHER	
OPTION	CODER FOR PRINTING DATE HOLE PUNCH NITROGEN FEEDING	

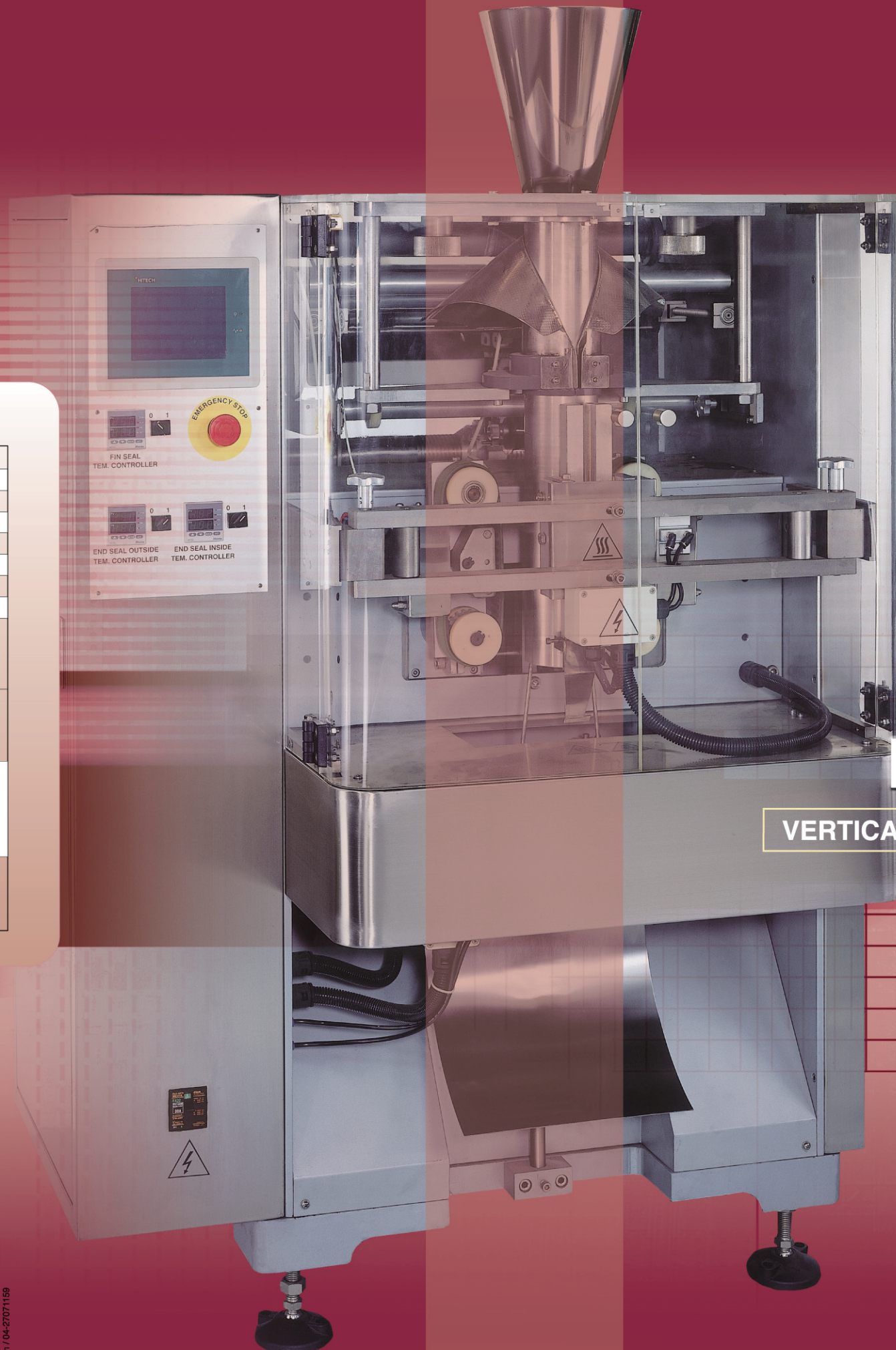

HERSONBER

VERTICAL FORM-FILL-SEAL MACHINE



HERSONBER INDUSTRIAL CO., LTD.

No. 18 Lane 156, Feng Nan St., Feng Yuan, Taiwan.

TEL: +886-4-25235829 FAX: +886-4-25276923

E-mail: hsbpack@seed.net.tw

http://www.hersonber.com

AGENT

VERTICAL FORM-FILL-SEAL MACHINE

Advanced PLC control with touch screen. Labor saving. Low maintenance. Quick size change. Cost saving.



FEATURES:

- ▲ With touch screen to display machine state, operation instruction, the state of breakdown.
- ▲ Over 30 sets of products specifications can be stored in the machine.
- ▲ On-line adjustments of sealing and cutting position, very easily made on the touch screen.
- ▲ With AC servomotor for film feed draw belt, resulting in creating smooth operation and high speed.



HW-5152

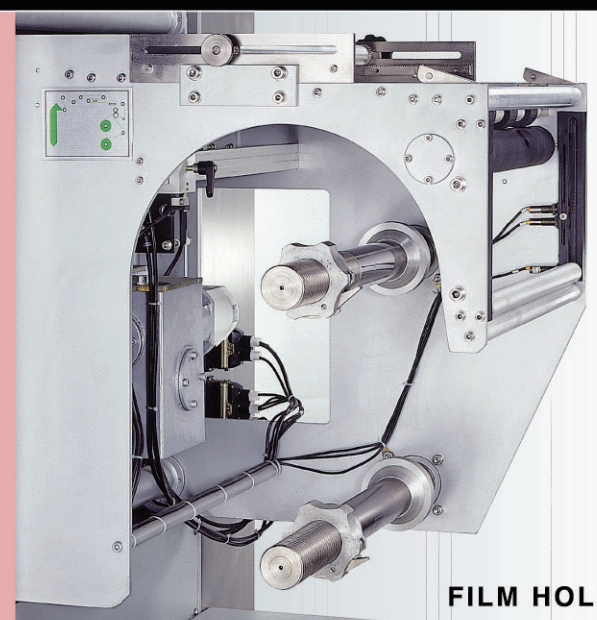

FILM HOLDERS



CONVEYOR

CODER FOR PRINTING DATE

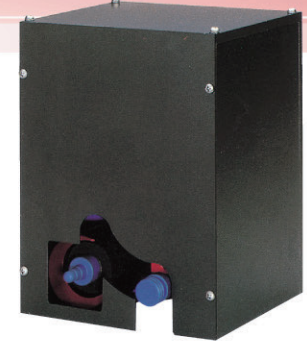

AUGER FILLER

MULTIHEAD COMBINATION WEIGHER

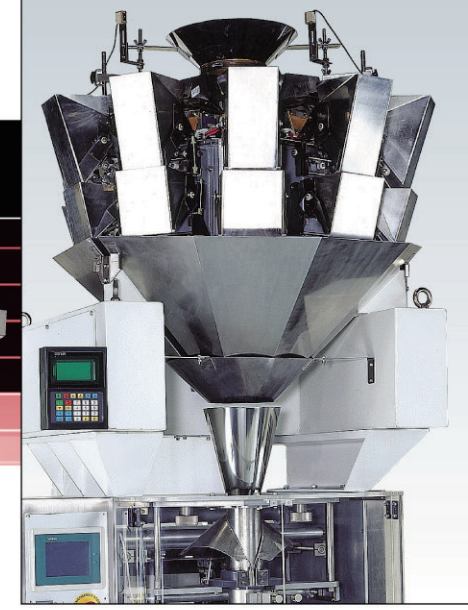

VOLUMETRIC CUPS

